

HARLO[®] PRODUCTS

MATERIAL HANDLING DIVISION

HP 5000

**2W & 4W Drive
5000 lb. Capacity
Powered by Cummins Engine
Side Shift Masts**

**Agriculture
Construction
Turf
Forestry
Lumber
Mining
Transportation
Industrial**

ROUGH TERRAIN FORKLIFTS

No matter what business your're in, this rough terrain forklift

WILL DO THE JOB.

HARLO PRODUCTS

P.O. Box 129 | Grandville, MI 49468

P. 616-538-0550 | F. 616-538-1264

www.harlo.com | sales@harlo.com

POWERED BY



Unit shown with optional Bin Clamp

HARLO HP5000 FORKLIFT SPECIFICATIONS - CUMMINS ENGINE

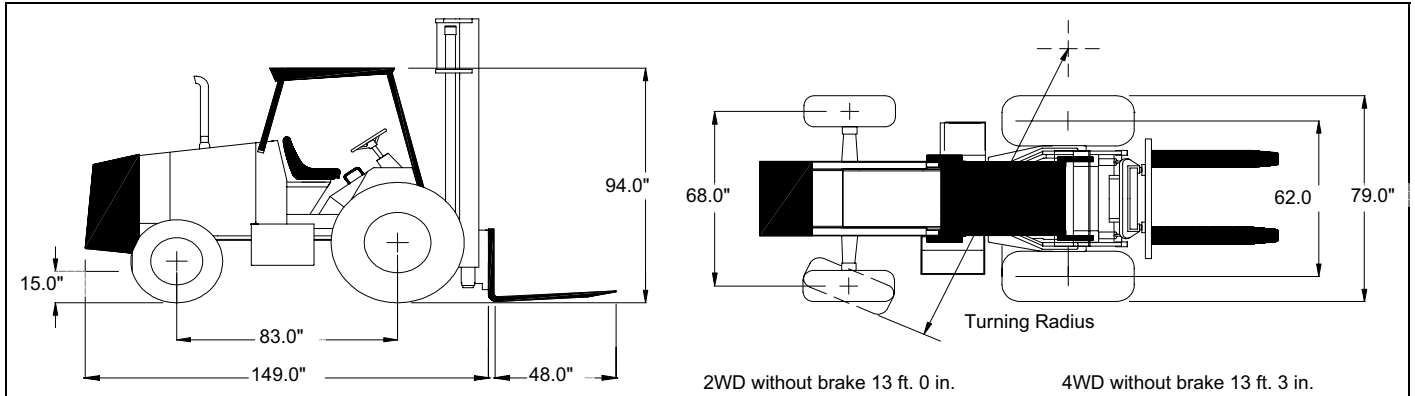

2WD without brake 13 ft. 0 in.

4WD without brake 13 ft. 3 in.

ENGINE		BRAKES						
Make and Model	Cummins 4B4.5NA	Service Brakes	Hydraulic Multi-wet Disc, Mounted Inboard, Self adjusting and Equalizing Cable Activated, Independent of Service					
Type	4 Cycle Diesel	Park Brake	Cable Activated, Independent of Service					
Aspiration	Naturally	DIMENSIONS						
Number of Cylinders	4	Ht. top Overhead Guard	94 in.					
Displacement	275 cu. in.	Wheel Base	83 in.					
Bore	4.02 in.	Drive Tread Width	62 in.					
Stroke	5.42 in.	Steer Tread Width (2WD)	68 in.					
Compression Ratio	18.0:1	Steer Tread Width (4WD)	66 in.					
Net Engine Horse Power	80 hp @ 2500 rpm	Underclearance	15.0 in.					
Maximum Net Torque	222 ft-Lbs @ 1300 rpm	Mast Tilt	13° Forward; 13° Rearward					
Fuel Injection	Rotary Pump, Direct Injection	Overall Width	79 in.					
ELECTRICAL SYSTEM		Overall Length (less forks)	149 in.					
Voltage	12 Volt	CAPACITIES						
Alternator	65 amp.	Fuel Tank	21.5 U.S. Gal					
Battery Rating	950 CCA, 190 Min. Reserve (79 Ah)	Cooling system	3.9 U.S. Gal					
HYDRAULIC SYSTEM		Engine Oil with Filter	9 qts					
Type	Independent	Torque Converter and Transmission	20.5 qts					
Pump Type	Gear	Hydraulic System	12.5 U.S. Gal					
Pump Capacity	30 gpm @ 2200 rpm	Powered Steer Axle	1.8 U.S. Gal					
System Pressure	2200 psi	Rigid Drive Axle	4.6 U.S. Gal					
TRANSMISSION		DRIVE AXLE						
Four Speed Transmission, Synchronized in all Gears with Hydraulic Reverser - Shift on the Go		Final Drive	Inboard Planetary					
Torque Converter	Single Stage, Dual Phase with 2.63:1 Stall Ratio	Differential Lock	Hydraulic with Foot Switch					
STEERING SYSTEM		TIRE SIZE						
Type	Hydrostatic Power Steering	Drive (2WD & 4WD)	16.9-24, 10 Ply					
Turns Lock to Lock	2.5	Steer (2WD)	11L16, 10 Ply					
Axle Oscillation	20°	Steer (4WD)	12-16.5, 10 Ply					
MAST OPTIONS								
Capacity	Lift Height	Overall Lowered	Overall Extended	Carriage Width	2WD Weight	4WD Weight	Free Lift	Capacity @ 24" Load Center
5,000 lbs.	12 ft. 2 Stg.	110 in.	-	42 or 48 in.	11,600 lb.	11,800 lb.	None	5,000# to 12'
5,000 lbs Free Lift	14 ft. 3 Stg.	94 in.	-	42 in.	11,850 lb.	12,050 lb.	58 in.	5,000# to 14'

Contact Harlo for special masts.

Mfg. By: **HARLO PRODUCTS CORPORATION**

Distributed by:

P.O. Box 129
 Grandville, MI 49468-0129
 (800) 391-4151
 Fax (616) 538-1264
 www.harlo.com